

4

3

2

1

D

D

C

C

B

B

A

A

A

A

4

3

2

1

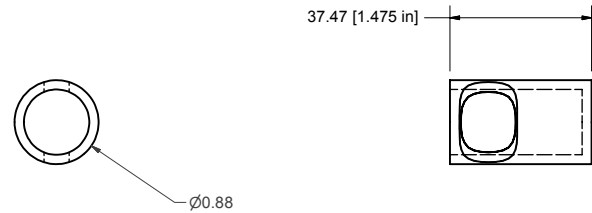
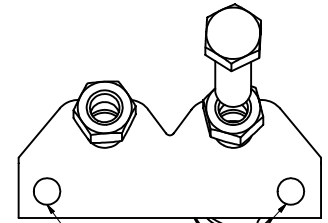
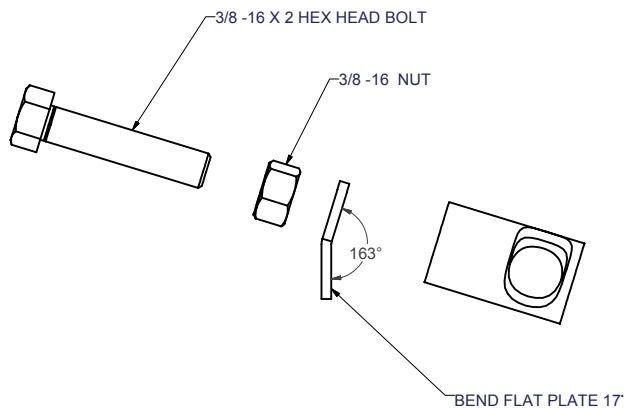
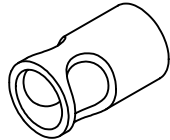
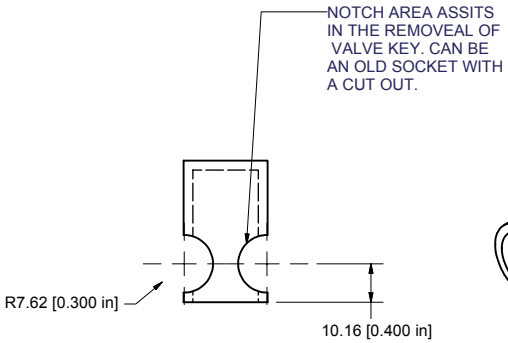

BRAZE OR WELD NUTS TO PLATE

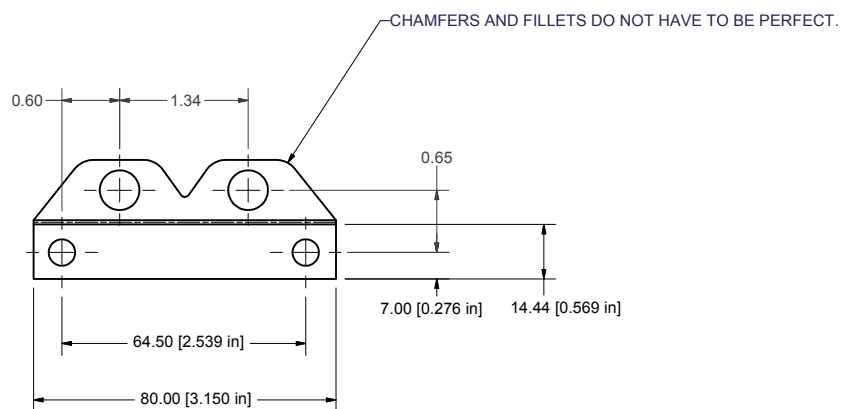
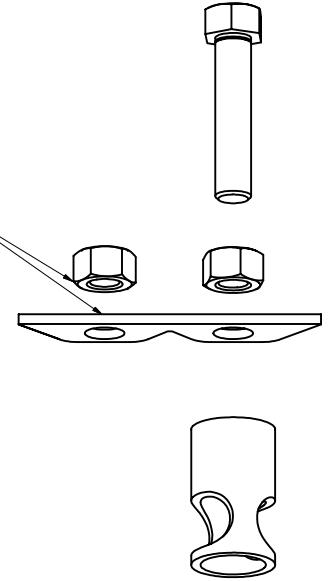

USE COMPRESSED AIR TO HOLD VALVES SHUT WHILE SPRING IS REMOVED.

DRAWN	T.CLINE	6/26/2002		
CHECKED			TITLE	
QA				
MFG				
APPROVED				
			SIZE	DWG NO
			C	Drawing1
			SCALE	REV
			SHEET	1 OF 2

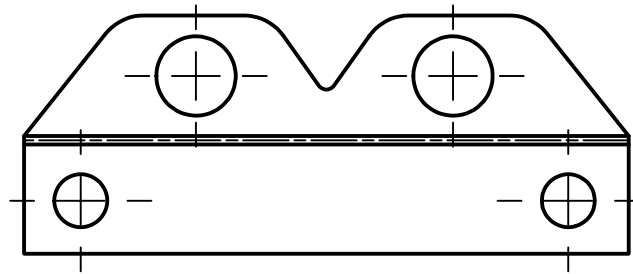

USE THIS AS A TEMPLATE TO CUT  
OUT YOUR PART AND DRILL  
HOLES.